

Planter Box Project Plans

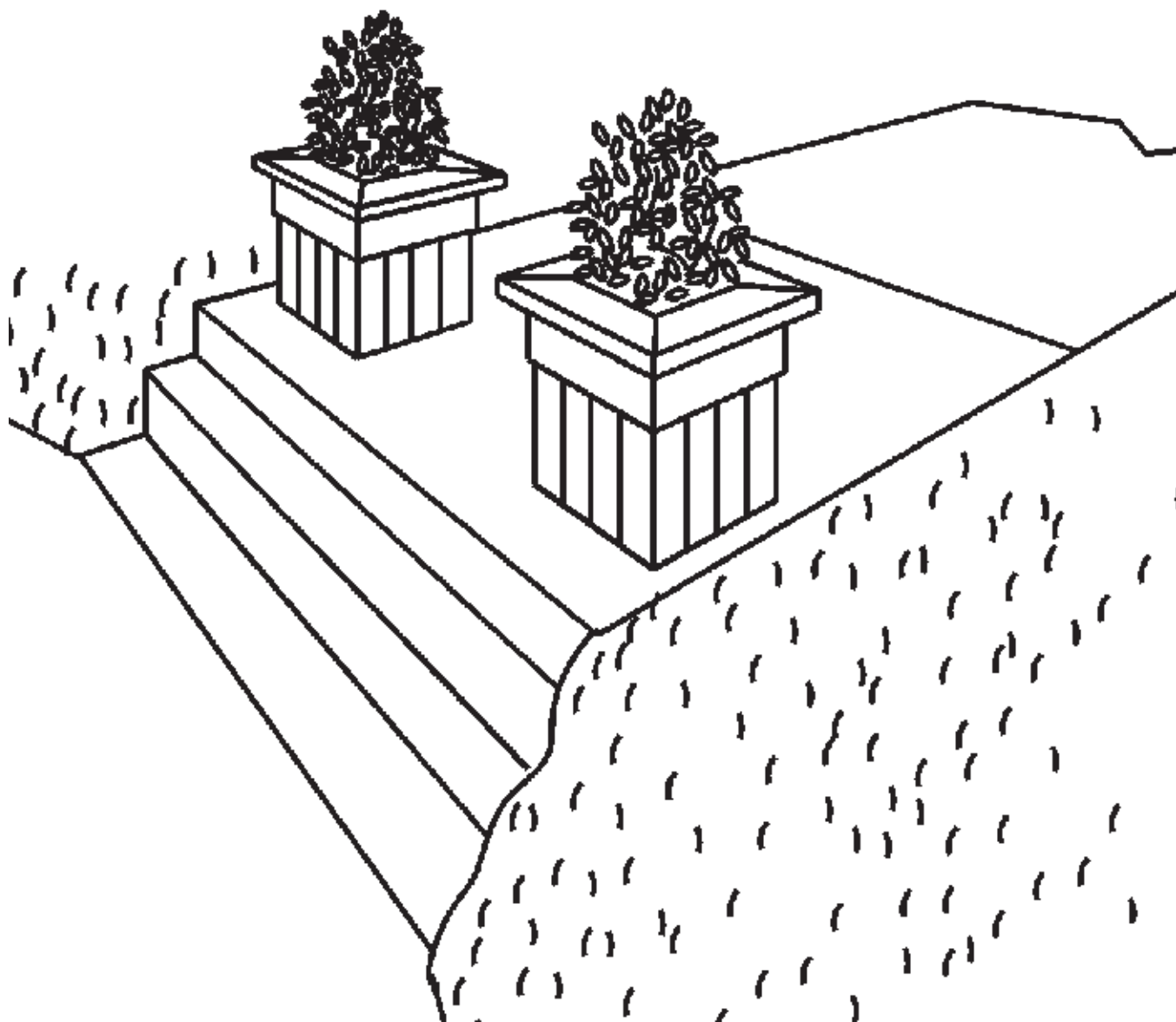

HARDWARE:

10d and 8d Hot-dipped, galvanized nails

TOP VIEW

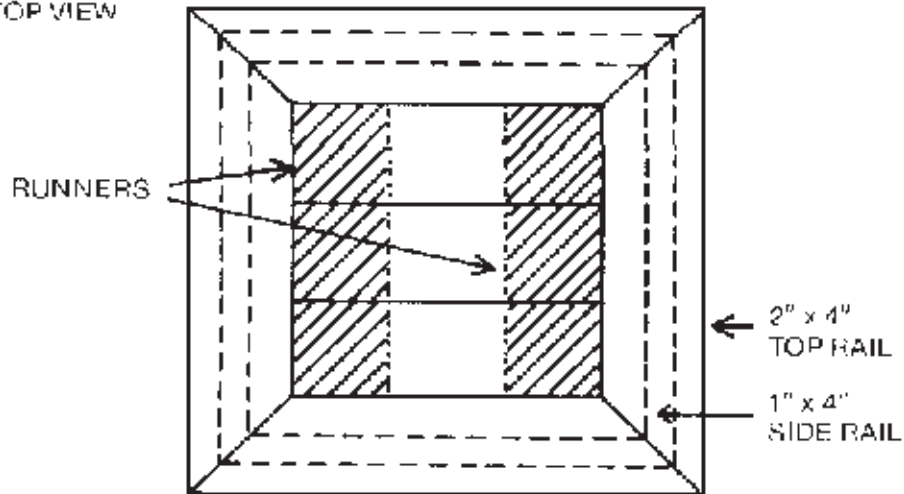

FRONT VIEW

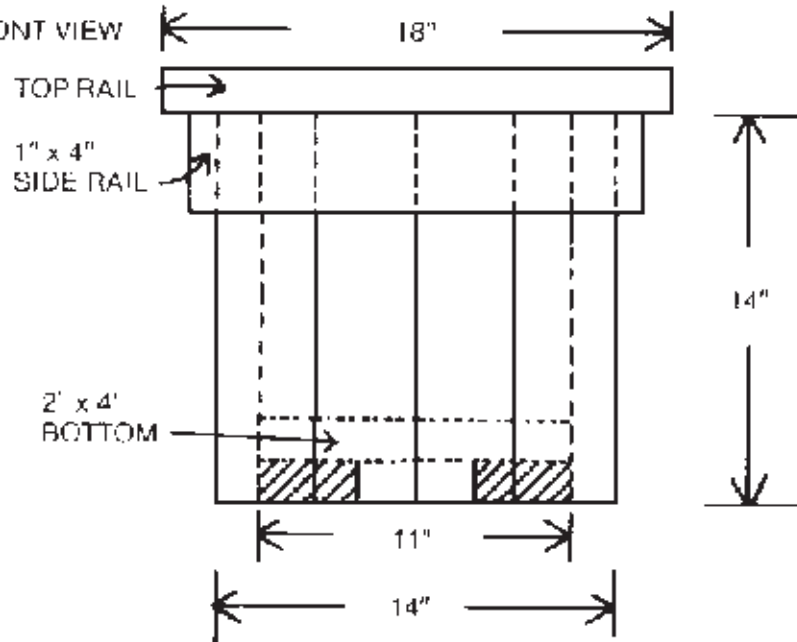

SIDE VIEW

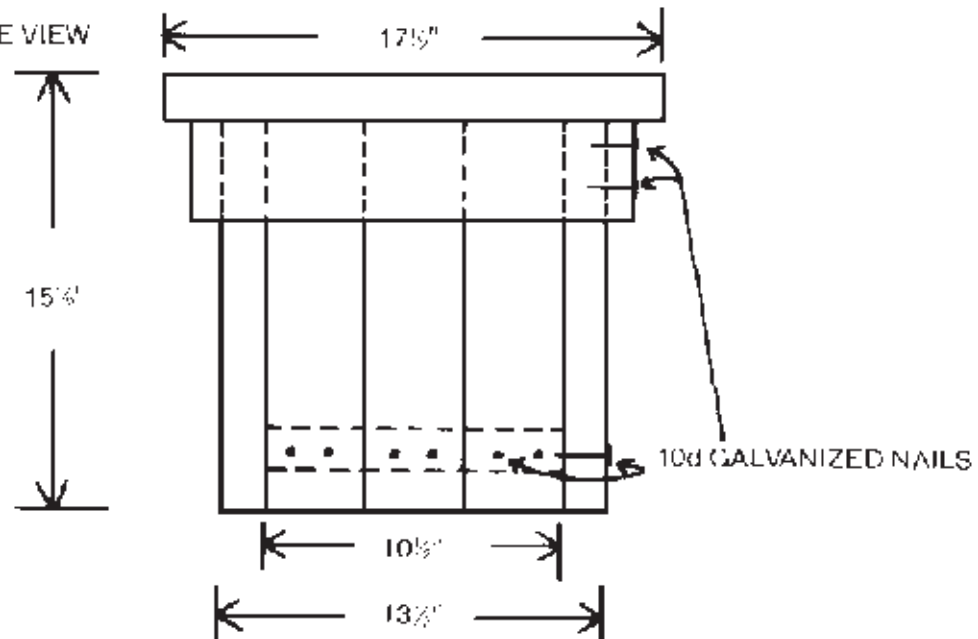

MATERIALS

PRESSURE TREATED LUMBER:

2 pcs	2" x 4" x 10½"	Bottom runners
3 pcs	2' x 4" x 11"	Bottom
8 pcs	2' x 4" x 14"	Front and back sides
6 pcs	2' x 4" x 14"	Left and right sides
4 pcs	1' x 4" x 18"	Side rails (<i>Extra board has been allowed for mitering.</i>)
4 pcs	2" x 4" x 20"	Top rails

TYPICAL CONSTRUCTION OF PLANTER BOXES

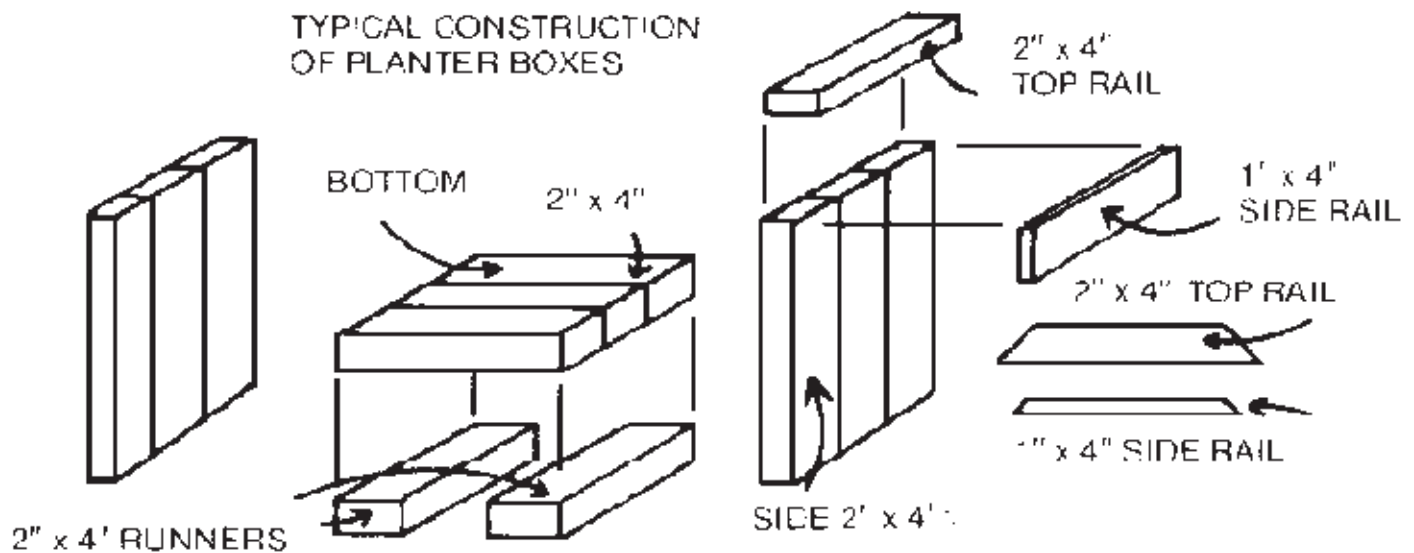

ORDER OF ASSEMBLY FOR PLANTERS

- Attach bottom 2" x 4"s to runners
- Attach side 2" x 4"s to bottom
- Attach front and back 2" x 4"s to bottom
- Attach top rails to box
- Attach side rails to box